

Ficha técnica :

# **150 AETJ-C**

---



Capacities		Métrico	Imperial
Working height	h21	15 m	49 ft 3 in
Platform height	h7	13 m	42 ft 8 in
Max. outreach	r1	7.6 m	24 ft 11 in
Overhang	h31	7 m	23 ft
Pendular arm rotation (top / bottom)		+65 ° / -65 °	+65 ° / -65 °
Platform capacity	Q	200 kg	440 lbs
Turret rotation		355 °	355 °
Platform rotation (right / left)		66 ° / 59 °	66 ° / 59 °
Number of people (inside / outside)		2 / 2	2 / 2
Weight and dimensions			
Platform weight*		6700 kg	14770 lbs
Platform dimensions (length x width)	lp / ep	0.92 m x 1.2 m	3 ft x 3 ft 11 in
Overall width	b1	1.5 m	4 ft 11 in
Overall length	l1	6.05 m	19 ft 10 in
Overall height	h17	1.97 m	6 ft 6 in
Overall length (stowed)	l9	4.4 m	14 ft 5 in
Overall height (stowed)	h18	2.08 m	6 ft 10 in
Floor height (access)	h20	0.4 m	1 ft 4 in
Jib length	l13	1.26 m	4 ft 2 in
Counterweight offset (turret at 90°)	a7	0.12 m	5 in
Internal turning radius (over tyres)	b13	1.87 m	6 ft 2 in
External turning radius	Wa3	3.96 m	13 ft
Tailswing		0.12 m	5 in
Ground clearance at centre of wheelbase	m2	0.14 m	6 in
Wheelbase	y	2 m	6 ft 7 in
Performances			
Drive speed - stowed		5 km/h	3.1 mph
Drive speed - raised		0.6 km/h	0.3 mph
Gradeability		22 %	22 %
Permissible leveling		3 °	3 °
Wheels			
Tyres type		Solid non-marking tires	Solid non-marking tires
Drive wheels (front / rear)		0 / 2	0 / 2
Steering wheels (front / rear)		2 / 0	2 / 0
Braking wheels (front / rear)		0 / 2	0 / 2
Engine/Battery			
Electric engine power rating		2 x 4.5 kW	2 x 4.5 kW
Electric Pump		3.7 kW	3.7 kW
Battery / Batteries capacity		48 V / 240 Ah	48 V / 240 Ah
Integrated charger (V / Ah)		48 V / 30 Ah	48 V / 30 Ah
Miscellaneous			
Number of cycles with STD Battery (HIRD)		46	46
Ground Pressure		13.5 daN/cm <sup>2</sup>	195.8 PSI
Hydraulic Pressure		210 Bar	14 PSI
Hydraulic tank capacity		15 l	3.96 US gal
Vibration on hands/ams		< 2.5 m/s <sup>2</sup>	< 2.5 m/s <sup>2</sup>
Standards compliance			
This machine is in compliance with:		European directives: 2006/42/EC- Machinery (revised EN280:2013) - 2004/108/EC (EMC) - 2006/95/EC (Low voltage)	European directives: 2006/42/EC- Machinery (revised EN280:2013) - 2004/108/EC (EMC) - 2006/95/EC (Low voltage)

# Diagramas de carga

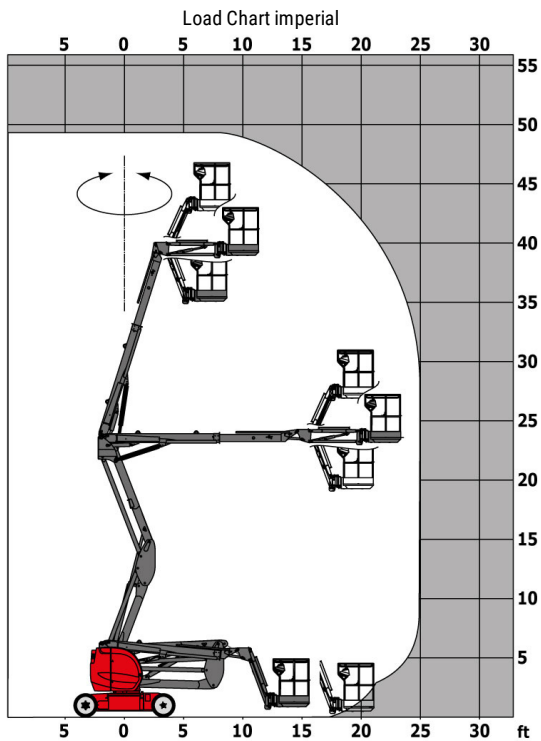
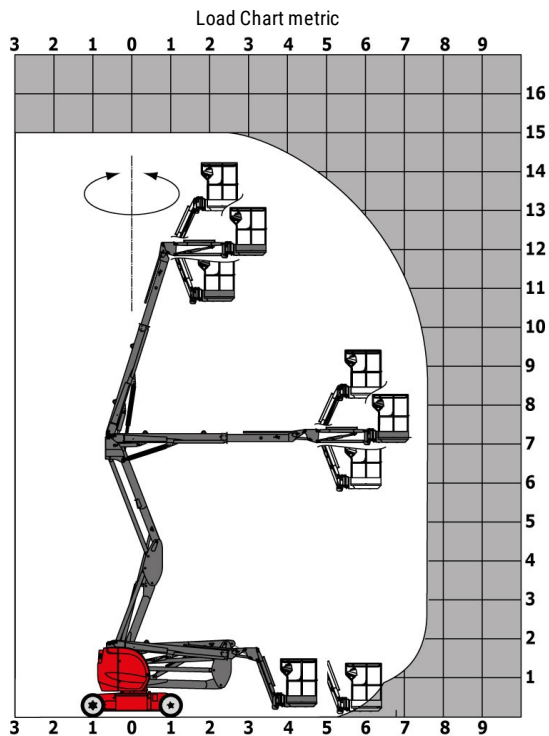

# Esquemas dimensionais

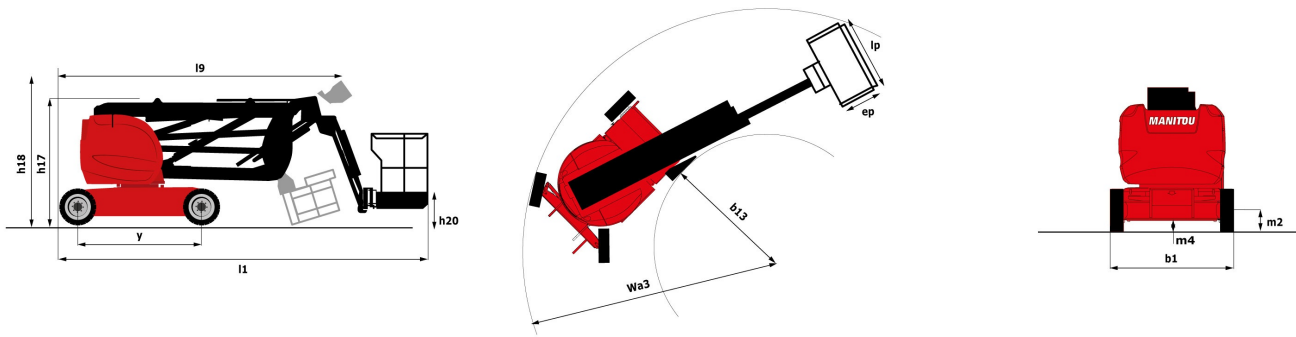

# Equipamentos

## Standard

230V Predisposition

Audible alarm and illuminated indicator lamp (leveling, overload, lowering)

Battery charge indicator lamp

CAN bus technology

Easy Manager

Emergency stop button in platform and on frame

Hom in the platform

Hour meter

Integrated diagnostic assistance

Manual emergency lowering

Multi-voltage integrated charger

Negative-type braking on rear wheels

Non-marking rubber tyres

Pendular arm

Platform with open-work floor

Proportional controls

Slings and securing rings

Tool box in platform

Traction battery

Travel possible at maximum height

## Opcional

110 or 230V plug with differential circuit breaker

3D

Air predisposition

Beep on every movement

Beep upon travel

Biodegradable oil

Centralized recharging of battery

Extreme cold oil

Flashing Light

Highly capacity battery

Maintenance-free battery

Personalized paintwork

Protective cover for control panel

SMS : Safe Man System

Safety harness

Water predisposition

Working headlight in platform



Siège Social

430 rue de l'Aubinière - 44150 Ancenis Cedex - France

Tel: +33(0)2 40 09 10 11 - Fax: +33 (0)2 40 09 10 97

[www.manitou.com](http://www.manitou.com)



Esta publicação apresenta uma descrição das versões e possibilidades de configuração dos produtos Manitou que podem possuir equipamentos diferentes. Os equipamentos apresentados nesta brochura podem ser de série, em opção ou não estarem disponíveis conforme as versões. A Manitou reserva o direito de modificar, em qualquer momento e sem pré-aviso, as especificações descritas e representadas. As especificações referidas não comprometem o fabricante. Para mais informações, contactar o seu concessionário Manitou. Documento não contratual. Apresentação de produtos não contratual. Lista de especificações não exaustiva. Os logótipos, assim como a identidade visual da empresa, são propriedade da Manitou e não podem ser utilizados sem autorização. Todos os direitos reservados. As fotografias e os esquemas contidos na presente brochura só são fornecidos para fins de consulta e a título indicativo.

MANITOU BF SA – Sociedade anónima com conselho de administração - Capital social: 39 668 399 euros - 857 802 508 RCS Nantes